

Rev	Date	Description

ALL DIMENSIONS IN (mm)
UNLESS OTHERWISE SPECIFIED
BREAK ALL SHARP EDGES

TOLERANCES
(BEFORE PAINTING
& AFTER PLATING)
X ± 1.00
X.X ± 0.50
X.XX ± 0.10
ANGLES ± 0.5°

A01- RENDER
CLIENT: RFA
PROJ. NO.: TBA
PART NO.: --
Revision --
Page 1

900mm (W) x 2415mm (H) x 450mm (D)
WALL BAY - PERFORATED
START BAY (MATTE BLACK)

PRODUCT CODE: **RFA2000**

Date: 9/11/2022

Drawn by DH

Checked by --

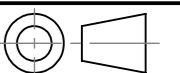

DO NOT SCALE

Scale@A3 1:20

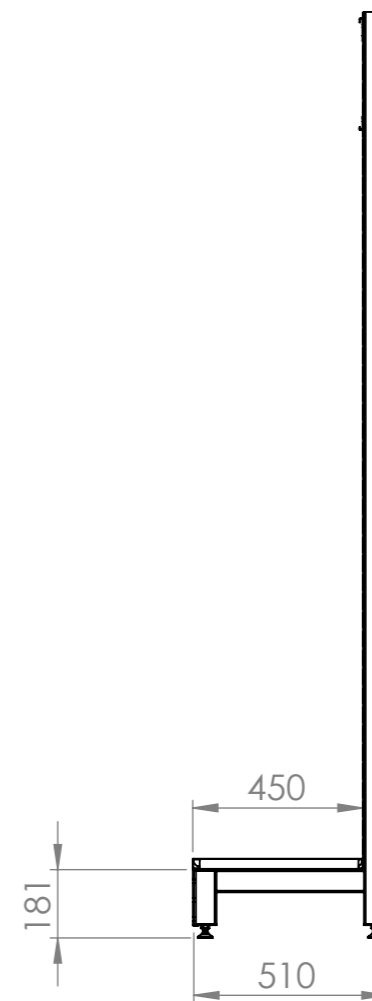
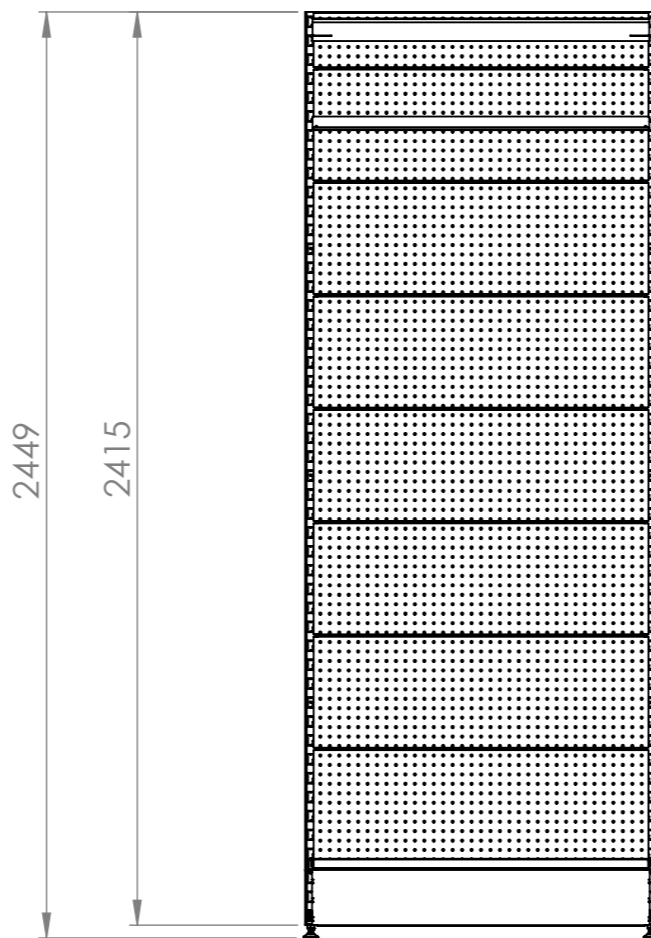
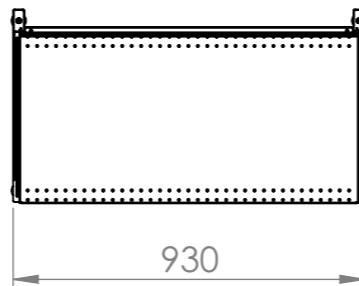
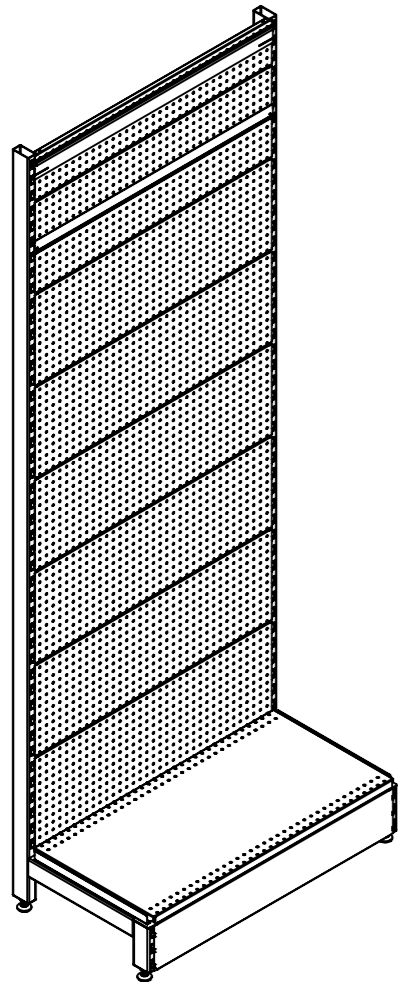

Rev	Date	Description

ALL DIMENSIONS IN (mm)
UNLESS OTHERWISE SPECIFIED
BREAK ALL SHARP EDGES

TOLERANCES
(BEFORE PAINTING
& AFTER PLATING)
X ± 1.00
X.X ± 0.50
X.XX ± 0.10
ANGLES ± 0.5°

A02- DIMENSIONS

CLIENT: RFA
PROJ. NO.: TBA
PART NO.: --
Revision --
Page 2

900mm (W) x 2415mm (H) x 450mm (D)
WALL BAY - PERFORATED
START BAY

PRODUCT CODE: -

Date: 9/11/2022

Drawn by DH

Checked by --

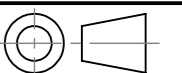

DO NOT SCALE

Scale@A3 1:20

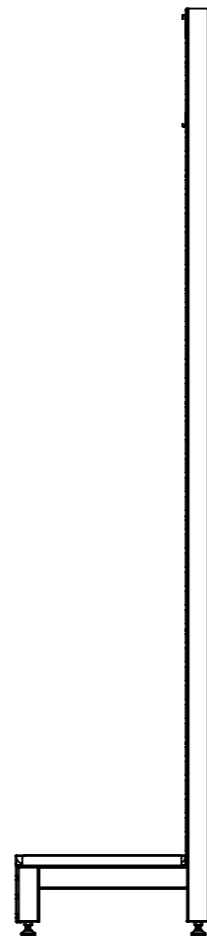
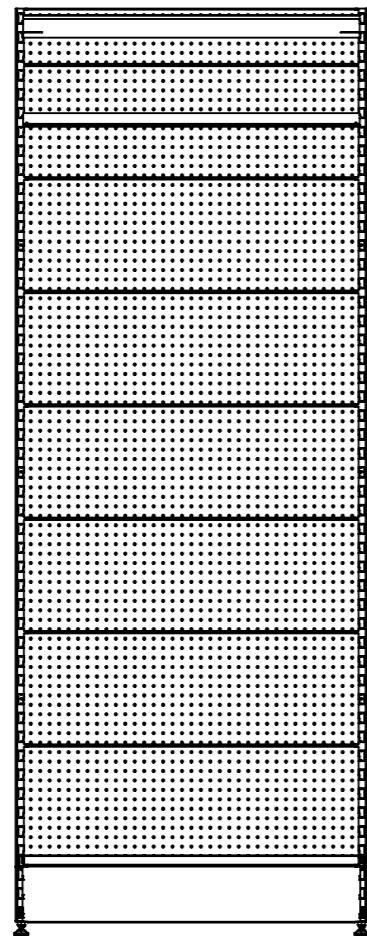
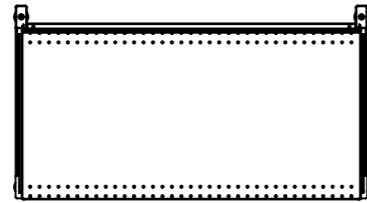
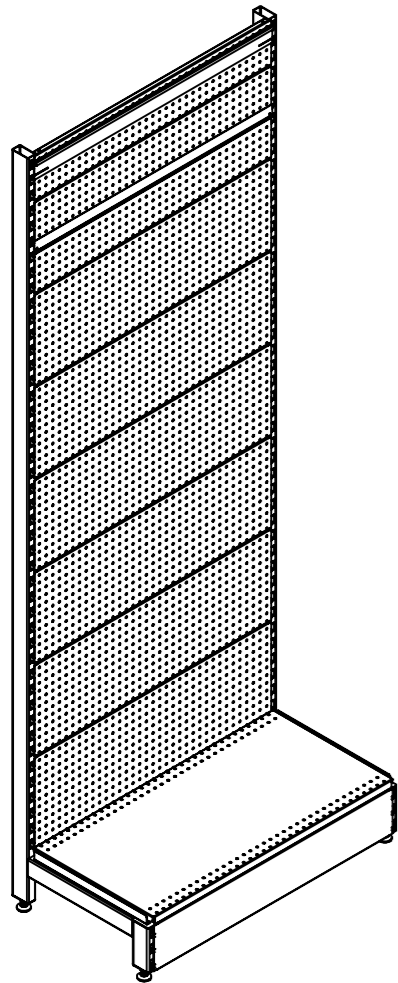

ITEM NO.	PartNo	DESCRIPTION	QTY.
1	RFA2100	2415mm(H)x450mm(D) WALL BAY POST	2
2		LEVELER	4
3		900mm(W)x300mm(H) PERFORATED PANEL	7
4		900mm(W)x150mm(H) PERFORATED PANEL	1
5		900mm(W)x150mm(H) BOTTOM SKIRT	1
6		900mm(W) SIGNAGE SUPPORT BRACKET-TOP	1
7		900mm(W) SIGNAGE SUPPORT BRACKET-BOTTOM	1
8		900mm(W)x450mm(D) STEEL SHELF	1

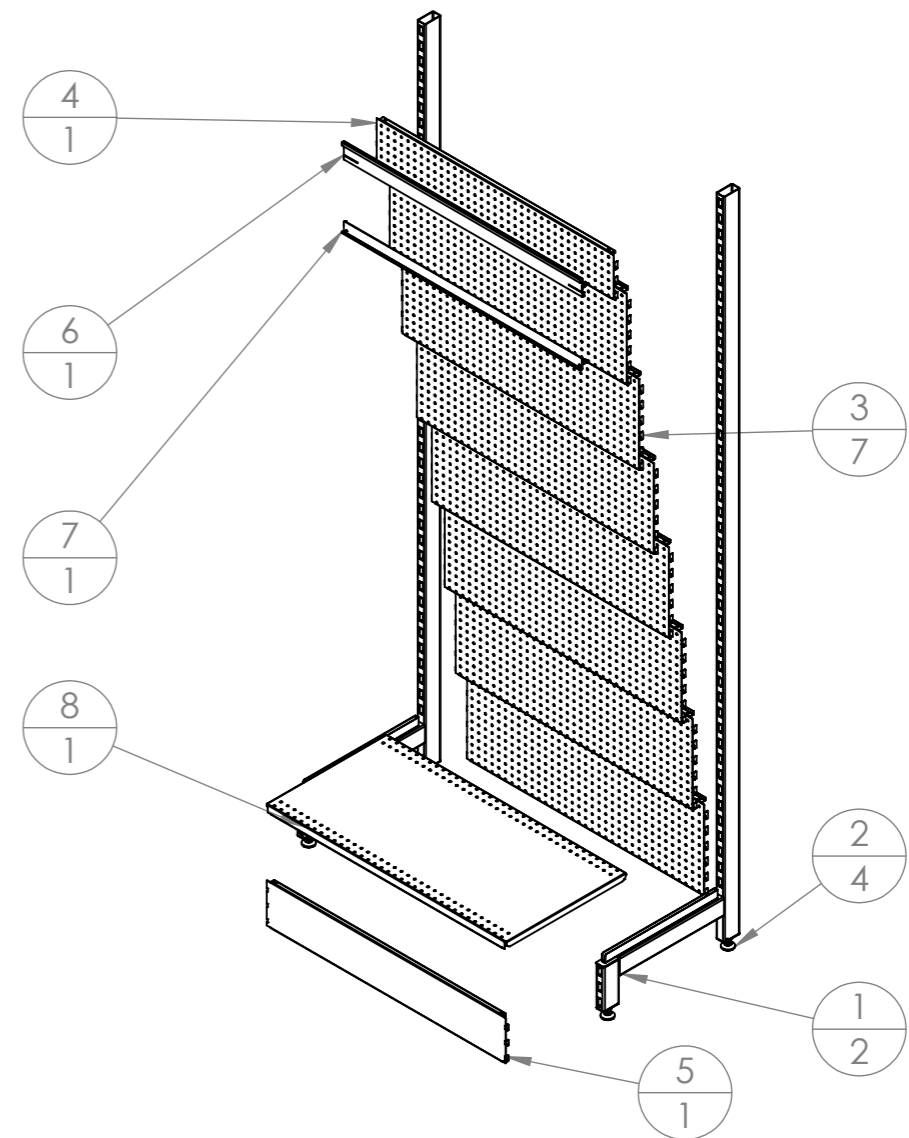

Rev	Date	Description

ALL DIMENSIONS IN (mm)
UNLESS OTHERWISE SPECIFIED
BREAK ALL SHARP EDGES

TOLERANCES
(BEFORE PAINTING
& AFTER PLATING)
X ± 1.00
X.X ± 0.50
X.XX ± 0.10
ANGLES ± 0.5°

A03- EXPLODED

CLIENT: RFA
PROJ. NO.: TBA
PART NO.: --
Revision --
Page 3

900mm (W) x 2415mm (H) x 450mm (D)
WALL BAY - PERFORATED
START BAY

PRODUCT CODE: -

Date: 9/11/2022

Drawn by DH

Checked by --

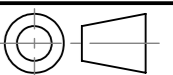

DO NOT SCALE

Scale@A3 1:20